

Micropulse AR Embeddable Rod Style

Rugged and Reliable Compact Housing

The Micropulse AR is a rugged, compact rod-style linear position transducer designed and built to meet the needs of demanding mobile hydraulic applications.

The Micropulse AR's stainless steel housing and compact size allow it to be completely embedded into a hydraulic cylinder for maximum protection against harsh environments.

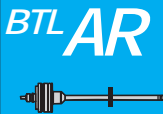
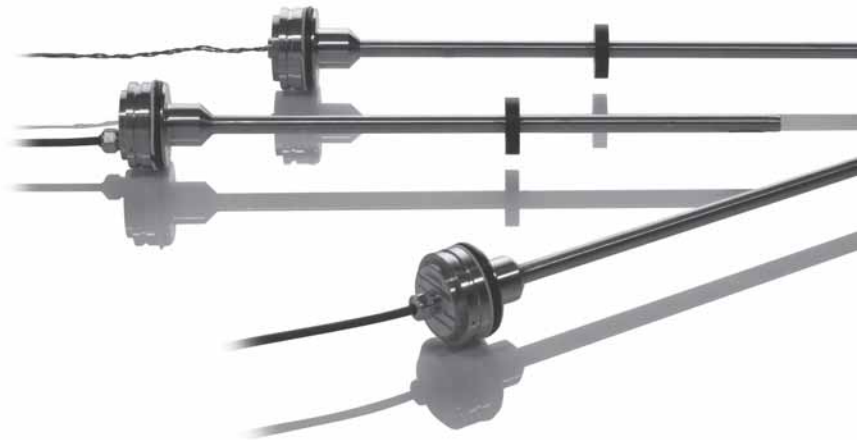

Features:

- Compact design for embedded cylinder applications
- Non-contact sensing technology
- No external electronics
- Analog outputs:
 - 0-10 Vdc
 - 0-5 Vdc
 - 4-20 mA
- Digital output:
 - RS422 Start/Stop

Applications:

Micropulse AR transducers are designed and tested to withstand the rigors of demanding mobile hydraulic applications, such as:

- Agricultural machinery
- Forestry machinery
- Earth moving equipment
- Construction machinery



General Specifications pg 48
 Electrical Options pgs 49-52
 Magnets pg 53
 Installation Guidelines pg 54

Series

AR Rod Style

Housing E2/E28,
BTL6-...-E2/E28-...-KA

Cable out
axial centric

PL0082a

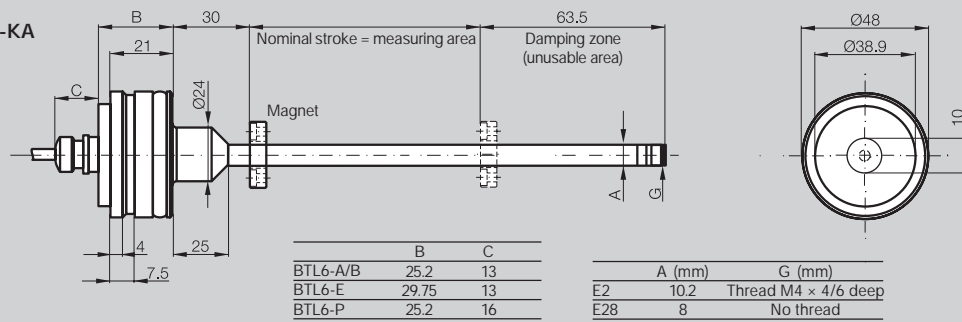

Housing E2/E28,
BTL6-...-E2/E28-...-LA

Cable out
axial with pigtail

PL0083a

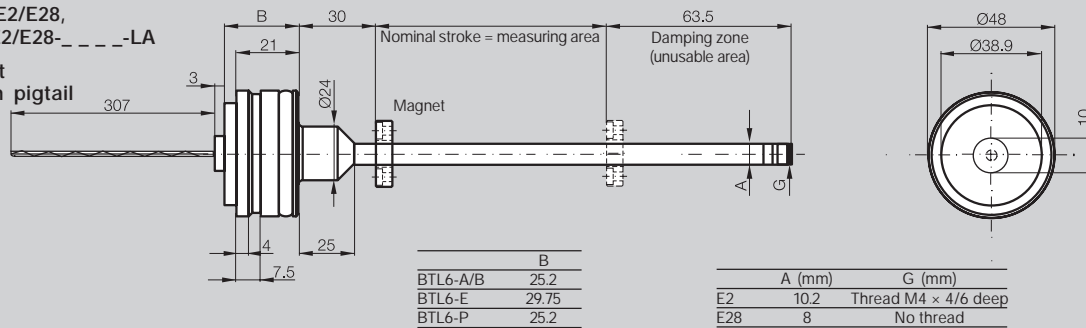

Housing E2/E28,
BTL6-...-E2/E28-...-KE

Cable out
axial eccentric

PL0084a

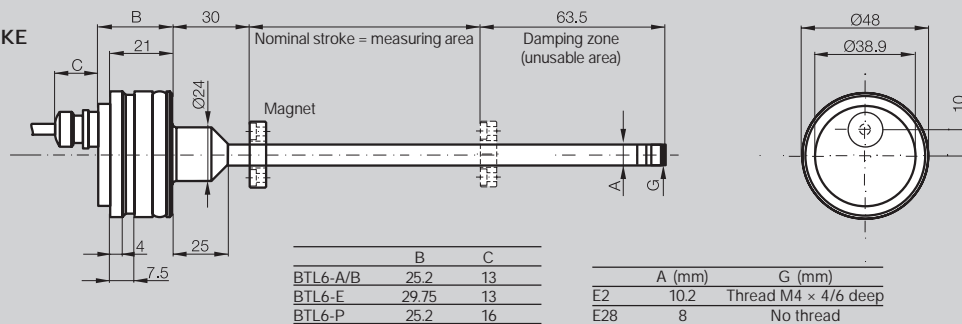

Ordering Code

BTL6-...-M-...-E2/E28-...-...

Shock Load	100 g/6 ms per IEC 60068-2-27
Continuous Shock	50 g/2 ms
Vibration	12 g, 10...2000 Hz per EN 60068-2-6
Polarity Reversal Protected	yes
Dielectric Strength	500 Vdc (GND to housing)
Protection per IEC 60529	IP 67
Housing Material	Outer tube 1.4571 stainless, flange 1.4404 stainless
Pressure Rating with 10.2 mm Outer Tube (E2)	350 bar when installed in hydraulic cylinder
Pressure Rating with 8 mm Outer Tube (E28)	250 bar when installed in hydraulic cylinder
Connection Type	Cable connection or pigtail
EMC Tests:	
RF Emission	EN 55011 Group 1, Class A/B
Static Electricity (ESD)	IEC 61000-4-2 Severity Level 3
Electromagnetic Fields (RFI)	IEC 61000-4-3 Severity Level 3
Rapid Transients (BURST)	IEC 61000-4-4 Severity Level 3
Surge Voltage	IEC 61000-4-5 Severity Level 2
Line-induced Disturbances	IEC 61000-4-6 Severity Level 3
Magnetic Fields	IEC 61000-4-8 Severity Level 4
Standard nominal stroke lengths [mm]	0025, 0051, 0076, 0090, 0102, 0127, 0152, 0178, 0203, 0230, 0254, 0280,
Max. stroke length for 8 mm outer rod (Style E28) = 1016 mm	0305, 0330, 0381, 0407, 0457, 0508, 0560, 0610, 0661, 0711, 0762, 0813, 0914, 1016, 1067, 1220, 1270, 1372, 1524

The propagation time of an ultrasonic wave, induced by magnetostriction, is used to determine the position of the magnet.

The position is output as an analog value which rises. This is done with high precision and repeatability within the measuring area designated as the nominal stroke length. If there is no magnet within the measuring area, an error signal is output. At the rod end is a damping zone. When a magnet is in this zone the output is spurious. The electrical connection between the transducer, the controller and the power supply is accomplished using a cable or pigtail.

Dimensions and mechanical data
page 48

Please order separately:
Magnets see page 53

Series	BTL6 Rod AR
Output Signal	analog voltage
Part No. Code (see page 50)	A

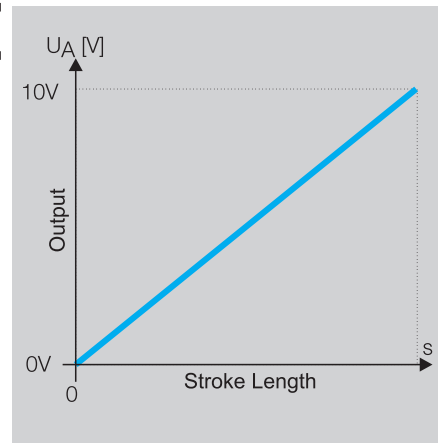

Ordering Code	BTL6-A500-M_____	
Output Voltage	0...10 Vdc	
Output Current	max. 2 mA	
Load Current	max. 2 mA	
Ripple Max.	≤ 5 mV	
Load Resistance	≤ 5 mV	
System Resolution	±1.5 mV	
Hysteresis	≤ 4 μm	
Repeat Accuracy	System resolution/min. 2 μm	
Sampling Rate	f _{STANDARD} = 1 kHz	
Max. Non-linearity	±200 μm up to 500 mm nominal stroke typ. ±0.02 % ≥ 500 nominal stroke	
Temperature Coefficient	Voltage Output	[150 μV/°C + (5 ppm/°C × P × U/L)] × DT
	Current Output	[0.6 μA/°C + (10 ppm/°C × P × I/L)] × DT
Supply Voltage	10...30 Vdc	
Current Draw	typ. ≤ 60 mA	
Polarity Reversal Protected	yes	
Overvoltage Protected	yes	
Dielectric Strength	500 Vdc (GND to housing)	
Operating Temperature	-40 to +185 °F	
Storage Temperature	-40...+212 °F	
Pin Assignments	Color	BTL6-A500...
Output Signals	GY	0 V output
	GN	0...10 Vdc
Operating Voltage	BU	GND
	BN	10...30 Vdc
Shield connected to housing		

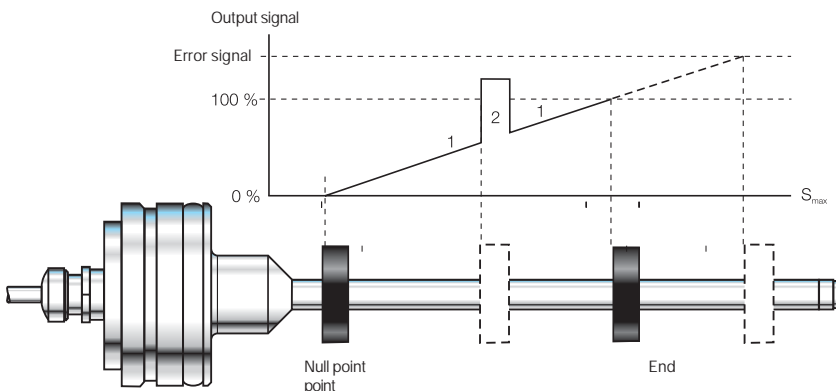
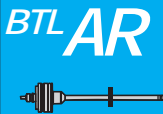

Output signal rising

Magnet position

- 1 Within the measuring area
- 2 Magnet not present

Series	BTL6 Rod AR	BTL6 Rod AR
Output Signal	analog voltage	analog current
Part No. Code (see below)	B	E

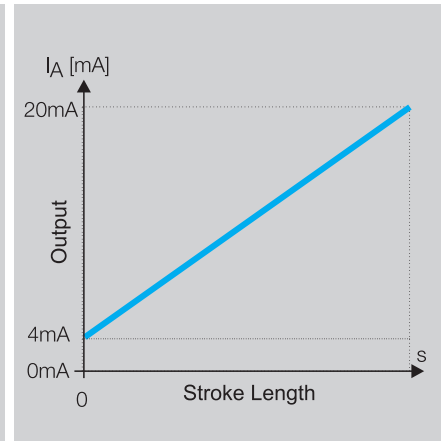
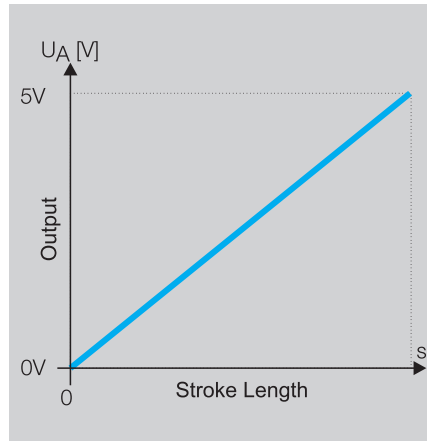

Ordering Code	BTL6-B500-M _____	BTL6-E500-M _____	
Output Voltage	0...5 Vdc		
Output Current		4...20 mA	
Load Current	max. 2 mA		
Ripple Max.	≤ 2 mV		
Load Resistance		≤ 500 Ohms	
System Resolution	±1.5 mV	±7 μA	
Hysteresis	≤ 4 μm		
Repeat Accuracy	System resolution/min. 2 μm		
Sampling Rate	f _{STANDARD} = 1 kHz		
Max. Non-linearity	±200 μm up to 500 mm nominal stroke typ. ±0.02 % ≥ 500 nominal stroke		
Temperature Coefficient	Voltage Output	[150 μV/°C + (5 ppm/°C × P × U/L)] × DT	
	Current Output	[0.6 μA/°C + (10 ppm/°C × P × I/L)] × DT	
Supply Voltage	10...30 Vdc		
Current Draw	typ. ≤ 60 mA		
Polarity Reversal Protected	yes		
Overvoltage Protected	yes		
Dielectric Strength	500 Vdc (GND to housing)		
Operating Temperature	-40 to +185 °F		
Storage Temperature	-40 to +212 °F		
Pin Assignments	Color	BTL6-B500...	BTL6-E500...
Output Signals	GY	0 V output	0 V output
	GN	0...5 Vdc	4...20 mA
Operating Voltage	BU	GND	GND
	BN	10...30 Vdc	10...30 Vdc

Shield connected to housing

Ordering example:

BTL6-500-M_____

Output signal

- A 0...10 V
- B 0...5 V
- E 4...20 mA

Standard

nominal stroke [mm]

- 0025, 0051, 0076, 0090, 0102,
- 0127, 0152, 0178, 0203, 0230,
- 0254, 0280, 0305, 0330, 0381,
- 0407, 0457, 0508, 0560, 0610,
- 0661, 0711, 0762, 0813, 0914,
- 1016, 1067, 1220, 1270, 1372,
- 1524

Consult factory for special lengths

Housing

- E2 outer tube
Ø 10.2 mm
- E28 outer tube
Ø 8 mm,
max. nominal
stroke 1016 mm

Connection type

- Axial out
KA02 PUR cable 2 m
- Axial eccentric out
KE02 PUR cable 2 m
- Axial out
LA00,3 PUR pigtail 0.3 m

P510 interface

Compatible with Balluff BTA processors, controllers, and modules from various manufacturers, including Siemens, B & R, Bosch, Phoenix Contact, Mitsubishi, Sigmatek, Parker, Esitron, WAGO, AB and others. Reliable signal transmission even over cable lengths of up to 500m between the BTA processor and the transducer is assured by the especially noise-immune RS485 differential drivers and receivers. Noise signals are effectively suppressed.

P510 universal for rising and falling edge evaluation

As a consequence of different control philosophies, digital pulse interfaces are available in two different types depending on the controller.

The difference is in which edge is used for processing. In the "P-interface" the falling edges are used for timing and in the "M-interface" the rising edges.

To reduce the number of different models to a minimum, the "P510-interface" was created as a universal pulse interface which combines both functions.

The reference point for the propagation time measurement is the "Start" pulse.

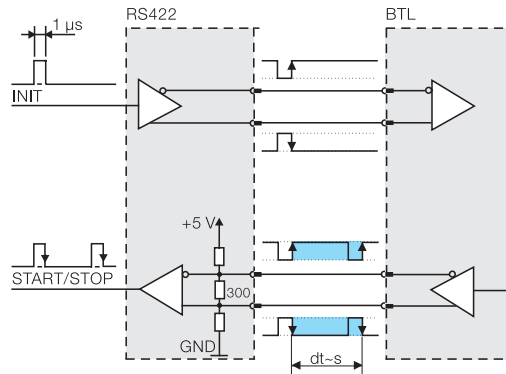

Block diagram of the P-interface

High-accuracy digitizing chip for P510 pulse interface

Companies who develop their own control and processing electronics can use the Balluff digitizing chip to implement a highly accurate P-type interface at low cost and without great effort. The digitizing chip was developed as a high-resolution, parameterizable ASIC for Micropulse transducers having a P-type pulse interface.

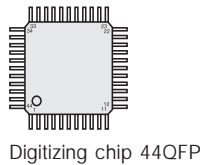

Digitizing chip 44QFP

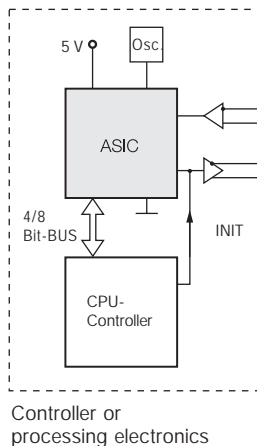

Controller or processing electronics

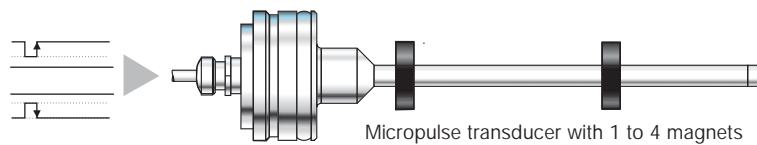

Micropulse transducer with 1 to 4 magnets

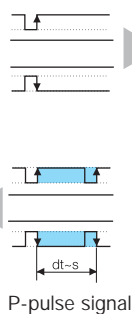

P-pulse signal

Advantages

- High displacement resolution: the actual resolution of the BTL displacement measuring system of 1 μm is fully supported by the resolution of the 133 ps chip (at low clock frequency 2 or 20 MHz)
- Position data from 4 magnets can be processed simultaneously
- 4-/8-bit processor interface



Series	BTL6 Rod AR
Part No. Code (see below)	P
Transducer Interface	Digital ST/SP Pulse

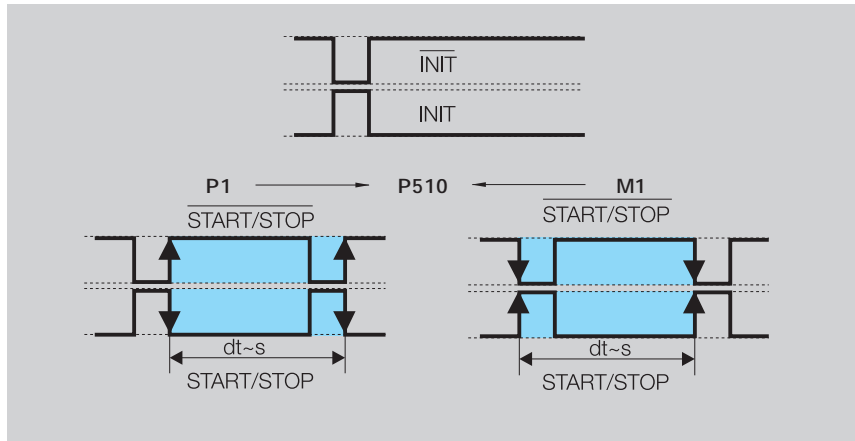

Ordering Code	BTL6-P510-M_ _ _ _ _	
System Resolution	processor-dependent	
Repeat Accuracy	≤ 10 μm	
Repeatability	≤ 20 μm	
Resolution	≤ 10 μm	
Non-linearity	±200 μm up to 500 mm nominal stroke typ. ±0.02 %, max. ±0.04 % 500...1500 mm nom. stroke length	
Supply Voltage	10...30 Vdc	
Current Draw	≤ 60 mA (at 1kHz)	
Operating Temperature	-40 to +185 °F	
Storage Temperature	-40 to +212 °F	
Pin Assignments	Color	BTL6-P510-M...
In-/Output Signals	Input YE	INIT
	Output GY	START/STOP
	Input PK	INIT
	Output GN	START/STOP
Operating Voltage	BU	GND
	BN	+24 Vdc

Shield connected to housing

Dimensions and mechanical data
page 48

Please order separately:
Magnets see page 53

Ordering example:

BTL6-P510-M_ _ _ _ _

Standard nominal stroke [mm]	Housing	Connection type
0025, 0051, 0076, 0090, 0102, 0127, 0152, 0178, 0203, 0230, 0254, 0280, 0305, 0330, 0381, 0407, 0457, 0508, 0560, 0610, 0661, 0711, 0762, 0813, 0914, 1016, 1067, 1220, 1270, 1372, 1524	E2 outer tube Ø 10.2 mm	Axial out KA02 PUR cable 2 m
	E28 outer tube Ø 8 mm, max. nominal stroke 1016 mm	Axial eccentric out KE02 PUR cable 2 m
		Axial out LA00,3 PUR pigtail 0.3 m

Description for Series	Magnet BTL6 rod	Magnet BTL6 rod	Magnet BTL6 rod	Magnet BTL6 rod
Ordering Code - Magnet	BTL-P-1013-4R*	BTL-P-1012-4R*	BTL-P-1014-2R	BTL-P-0814-GR-PAF
Ordering Code - Spacer	BTL Z-P-1013-4R-SPACER	BTL Z-2-1012-4R-SPACER	N/A	N/A
Material	Al	Al	Al	Ferrite PA 6
Weight	approx. 12 g	approx. 12 g	approx. 10 g	approx. 1.5 g
Magnet Traverse Speed	any	any	any	any
Operating Temperature/ Storage Temperature	-40...+100 °C	-40...+100 °C	-40...+100 °C	-40...+100 °C
Ordering Code PA 60 Fiberglass Reinforced	BTL-P-1013-4R-PA*	BTL-P-1012-4R-PA*		
Ordering Code - Spacer	SPACER BTL-P-1013-DR	SPACER BTL-P-1012-DR		
Material	PA 60 fiberglass reinforced	PA 60 fiberglass reinforced		
Weight	approx. 10 g	approx. 10 g		
Magnet Traverse Speed	any	any		
Operating Temperature/ Storage Temperature	-40...+100 °C	-40...+100 °C		

*Spacer is included with these magnets



Micropulse AR Style

Installation Guidelines

Micropulse AR style transducers are designed for integration in hydraulic cylinders. The transducer is mechanically supported at the housing. Three M5 set screws spaced at 120 °C hold the transducer, which fits into a Ø48 H8 hole.

Sealing is accomplished using the supplied O-ring and support ring. The magnet ring, which is integrated into the piston, marks the actual position of the piston as it moves without contact.

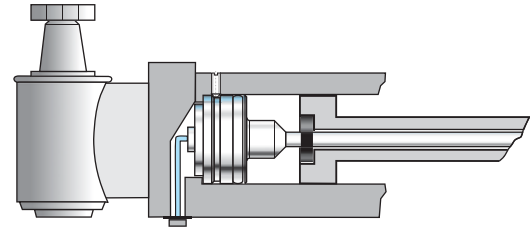
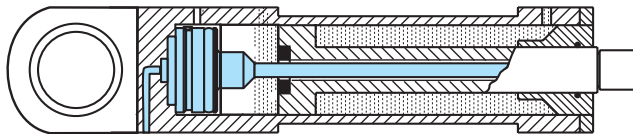

The metal surrounding of the cylinder replaces the needed cable shield when the BTL AR...LA, cable out pigtail version is installed in the cylinder. The pigtail version cannot be used without additional EMC protection (shield).

Set screw
DIN 914 M5x8

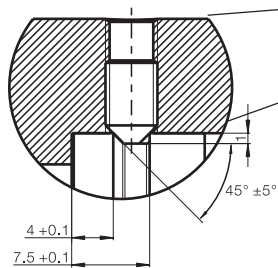

Fixing the transducer
using three M5 set
screws spaced 120 °C

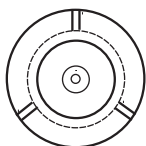

Installation Examples

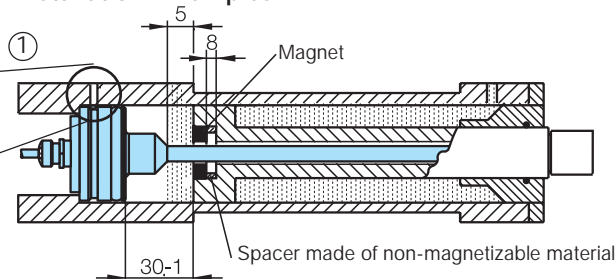

- ① Installation on piston side
- ② Installation from rear
- ③ Installation on piston side, in magnetic piston material

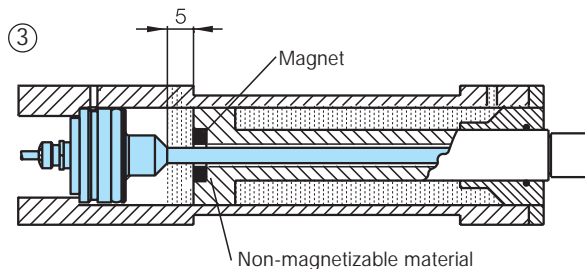
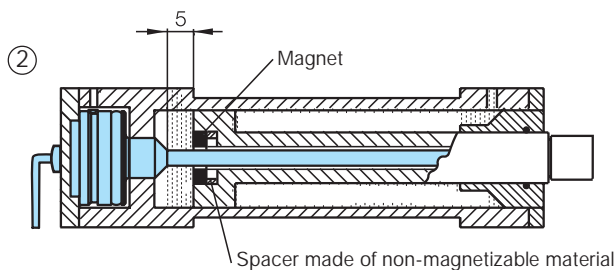

Note: Before construction, installation, and startup please familiarize yourself with the user's guide found at www.balluff.com.