

star

hydraulics ltd

SERVO TECHNOLOGY
AND RESEARCH

Model 892 Servovalve



- Nominal flows rates 95 to 230 l/min @ 70 bar
- Sapphire Technology
- Medium & High-Response characteristics
- External pilot supply
- Optional field replaceable filter
- Up to 500 bar supply pressure

Star Hydraulics Ltd.
8A Beta Close
Tewkesbury Industrial Centre
Tewkesbury
Gloucestershire GL20 8SR
England U.K.

Tel.: 01684 296176
Fax.: 01684 850714

Email: sales@star-hydraulics.co.uk
Web: <http://www.star-hydraulics.co.uk>

Nominal flow ratings	95, 150, 230 l/min at 70 bar p	
Hysteresis	< 4% without dither	
Threshold	< 1% without dither	
Null bias	< 2%	
Null shift	with 40°C temp change < 2% with 70 bar supply pressure change < 2% with return pressure 0 to 35 bar < 2%	
Pressure gain	< 1% rated input signal for 60% of supply pressure	
Seal materials available	FPM, NBR, EPDM	
Operating temperature range	-30 °C to 130 °C	
Proof pressure	at pressure port 150% max supply pressure at return port 100% max supply pressure	
Burst pressure	return port open 250% max supply pressure	
External leakage	Zero	
Degree of protection	IP 65 (BS EN 60529 : 1992)	
Weight	280 bar version 3.4 kg (w/ field filter 4.4 kg) 500 bar version 8.5 kg (w/ field filter 9.5 kg)	
Mounting position	Horizontal, fixed or movable	
Supply filtration	minimum ≥ 10 75 (10 micron abs) recommended ≥ 5 = 200 (5 micron abs)	
Fluid cleanliness level	minimum ISO 4406 - 16/13 NAS 1638 - class 7 recommended ISO 4406 - 13/10 NAS 1638 - class 4	
Supply pressure	min. to effect spool movement 5 bar minimum recommended 25 bar maximum continuous 210 bar (FPM & EPDM) 280 bar (NBR) high pressure option 500 bar (NBR) Ppilot limited to 280 bar	
Viscosity	VG 10 to 100 ISO 3448	
Fluid type	Petroleum based mineral oils For operation with other media contact factory	

Coil schematics

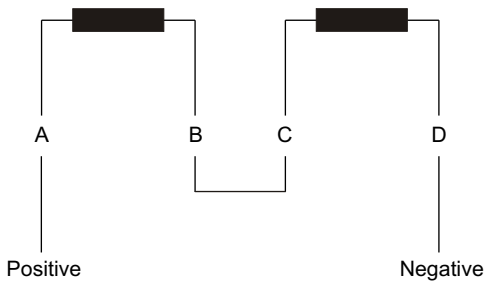

Series connection

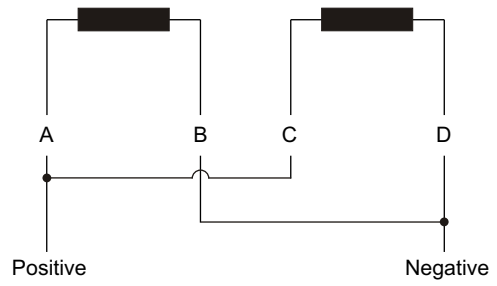

Parallel connection

Output flow polarity

Flow in the direction of P→C2, C1→R will occur with the pilot stage coils configured as above.

Coil options

Coil specification		Series connection		Parallel connection	
Rated signal [mA]	Resistance per coil [Ω]	Input current [mA]	Effective resistance [Ω]	Input current [mA]	Effective resistance [Ω]
10	1000	5	2000	10	500
15	200	7.5	400	15	100
20	1200	10	2400	20	600
30	300	15	600	30	150
30	800	15	1600	30	400
40	80	20	160	40	40
60	40	30	80	60	20
80	22	40	44	80	11
100	27	50	54	100	13.5
200	22	100	44	200	11

Electrical connection

Standard connector is MS3102E-14S-2P (MIL-C-5015). Please contact factory for more options.

Transient Response

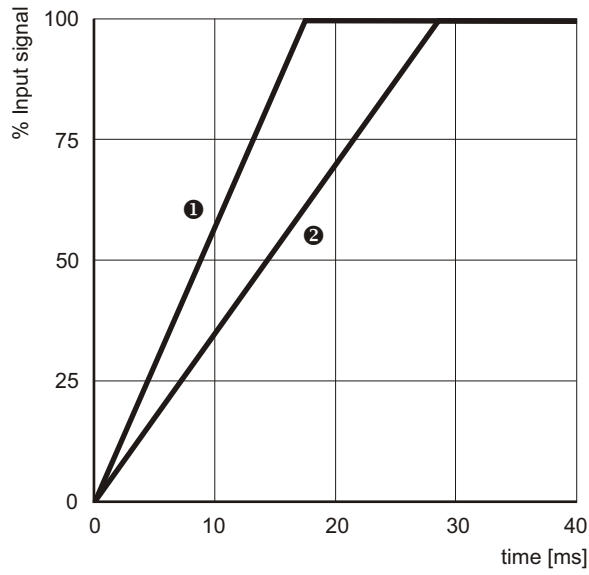

[1] Rated flow = 150 l/min
 [2] Rated flow = 230 l/min
 Supply pressure = 210 bar

Frequency Response

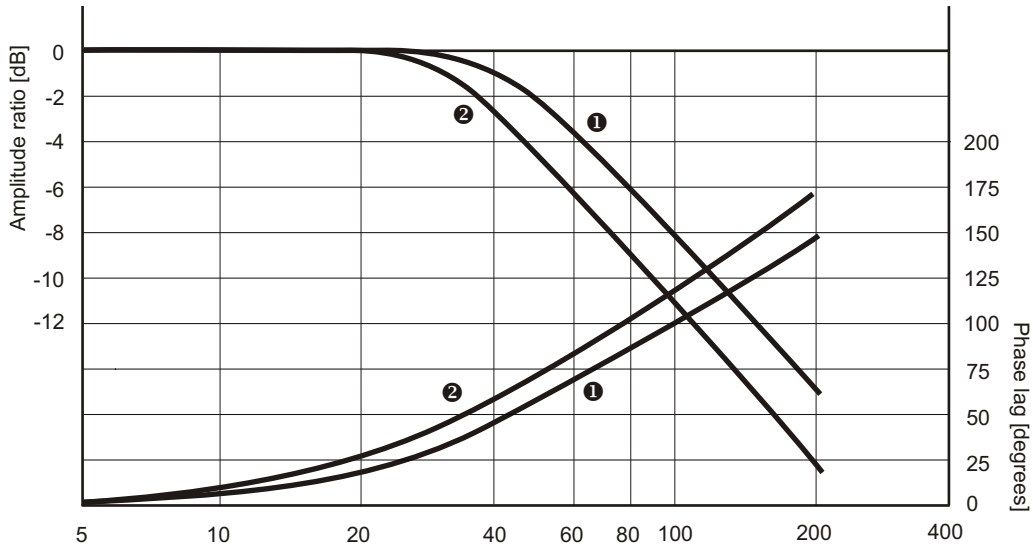

Input signal = 25%
 [1] Rated flow = 95 l/min
 [2] Rated flow = 230 l/min
 Supply pressure = 210 bar

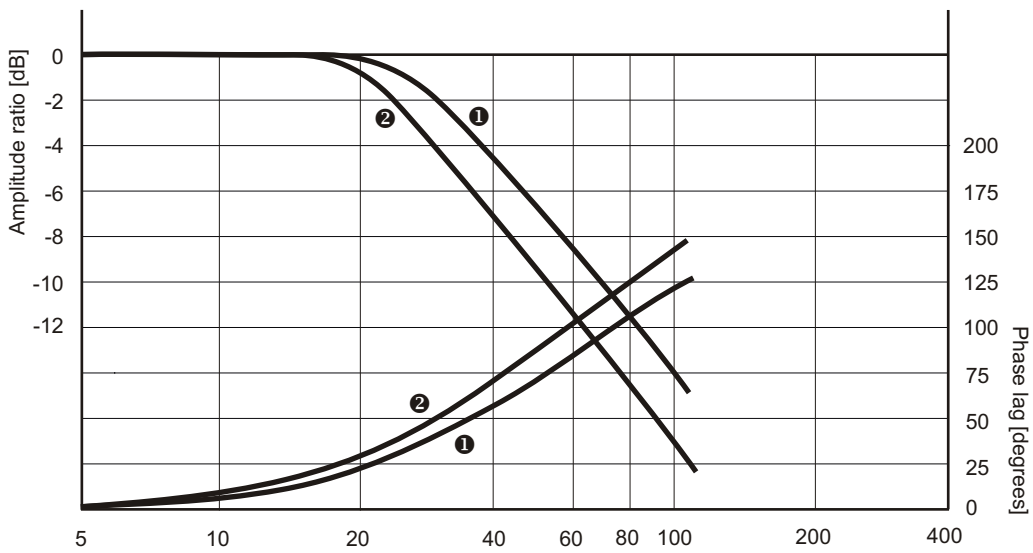

Input signal = 100%
 [1] Rated flow = 95 l/min
 [2] Rated flow = 230 l/min
 Supply pressure = 210 bar

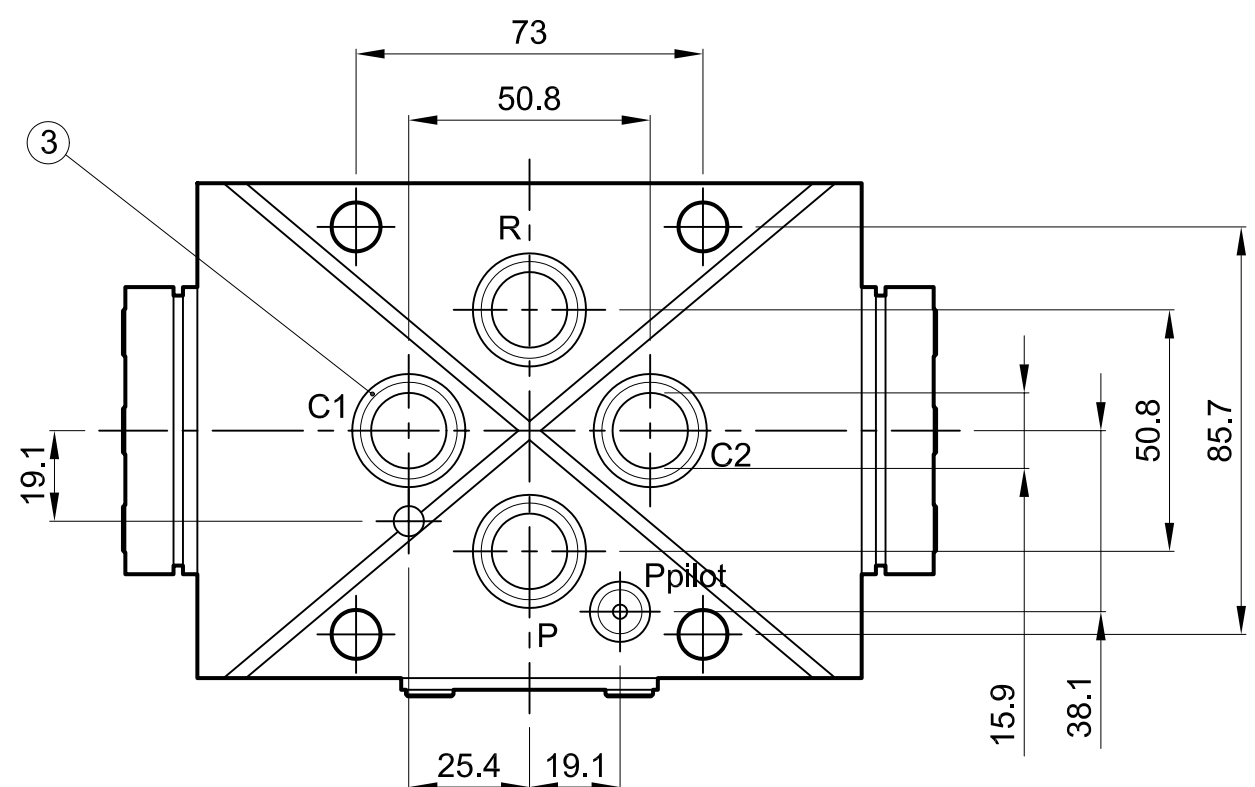
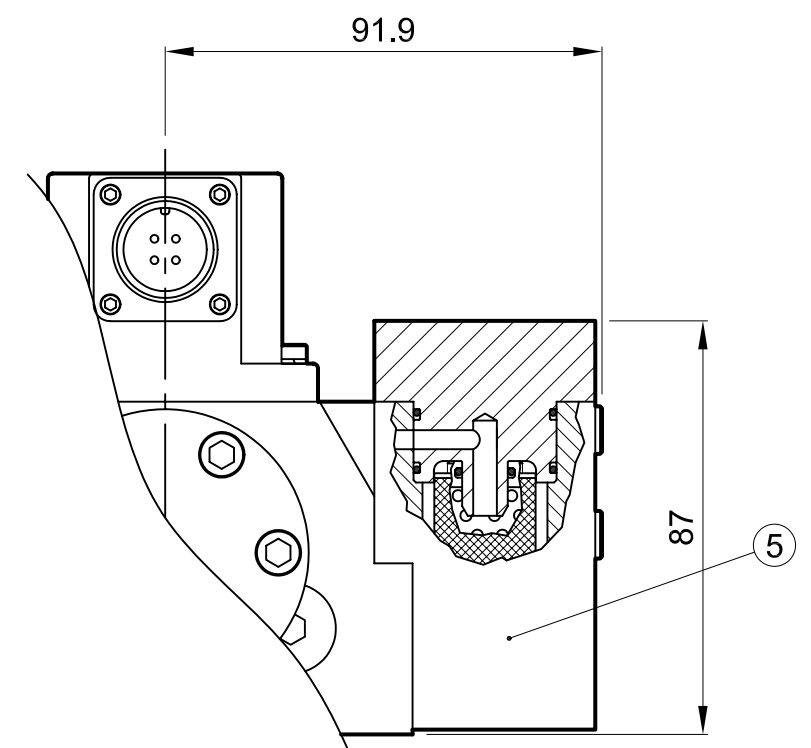
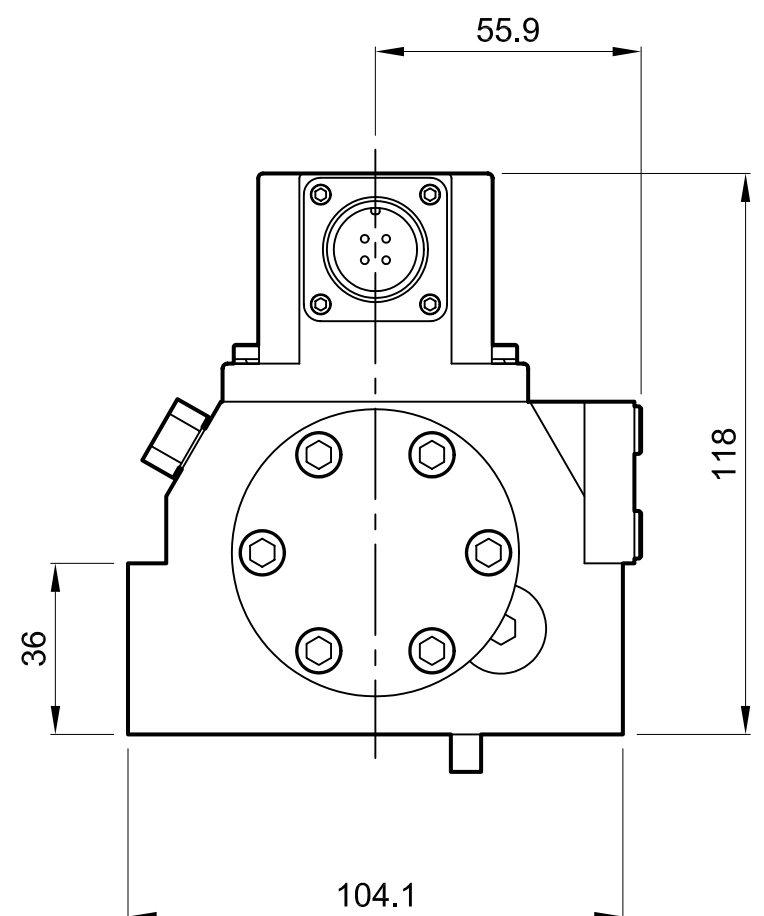
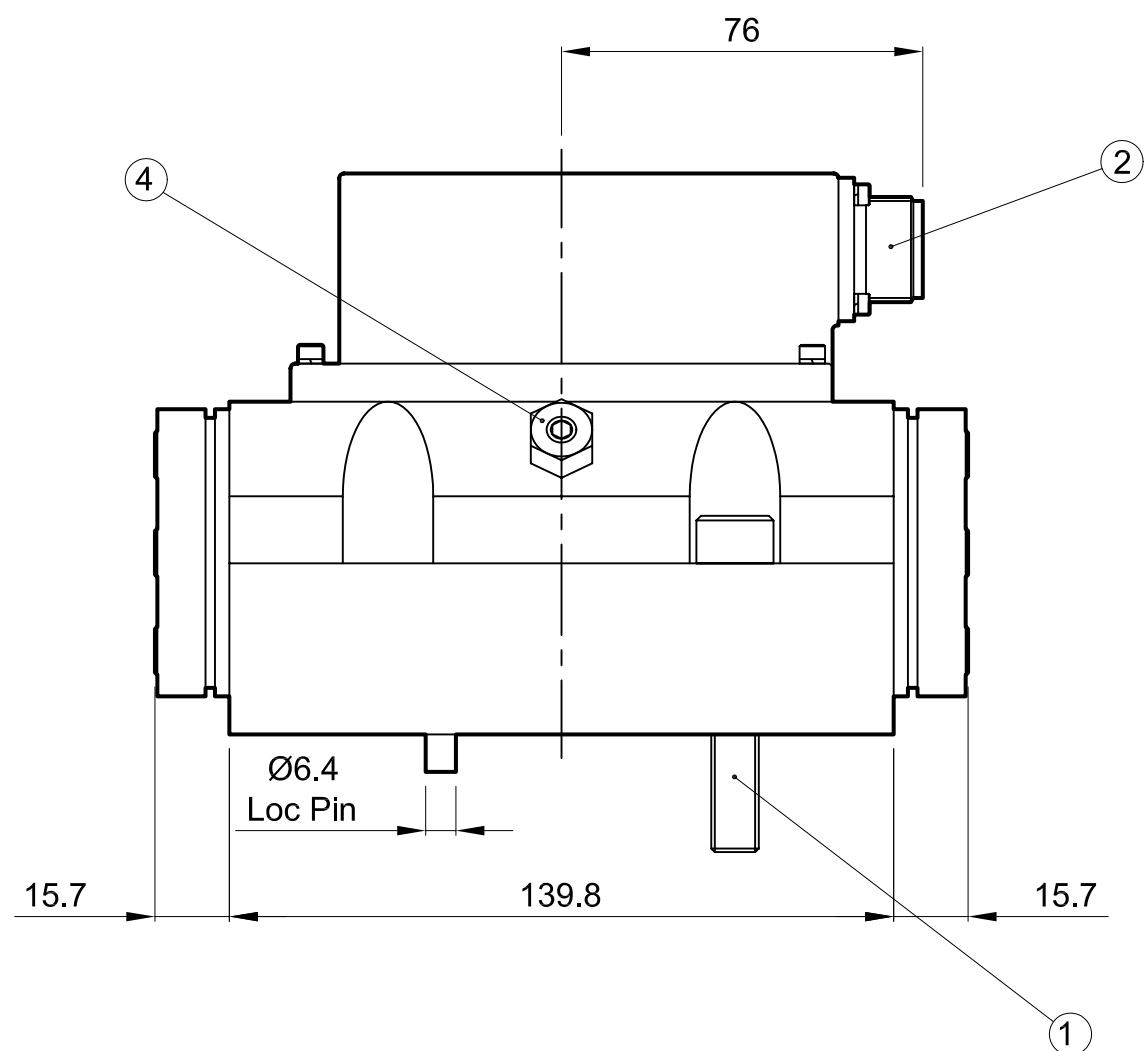

1. Suggested mounting bolts M10 x 60 long high tensile steel socket head cap screws.
2. 4-way electrical connector mates with MS3106-14S-2S or equivalent. Is available at 180° to position shown (advise desired position at time of order).
3. Base O-Rings: 20.35 I/D x 1.78 section (4 pcs). 9.25 I/D x 1.78 section (1 pc).
4. Null adjust requires 12 A/F ring spanner and 3.0 hexagon key. Flow out of C2 will increase with clockwise rotation of key.
5. Optional field replaceable filter housing. Element P/No. SRS1479.

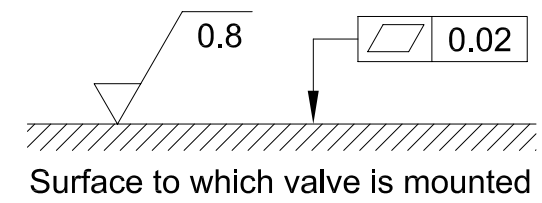

Installation Details Model 892	
Dimensions in millimeters 3rd angle projection	Filename

C/BORE FOR
LOC PIN
Ø8 X 10

Ø3
EXTERNAL
PILOT FEED

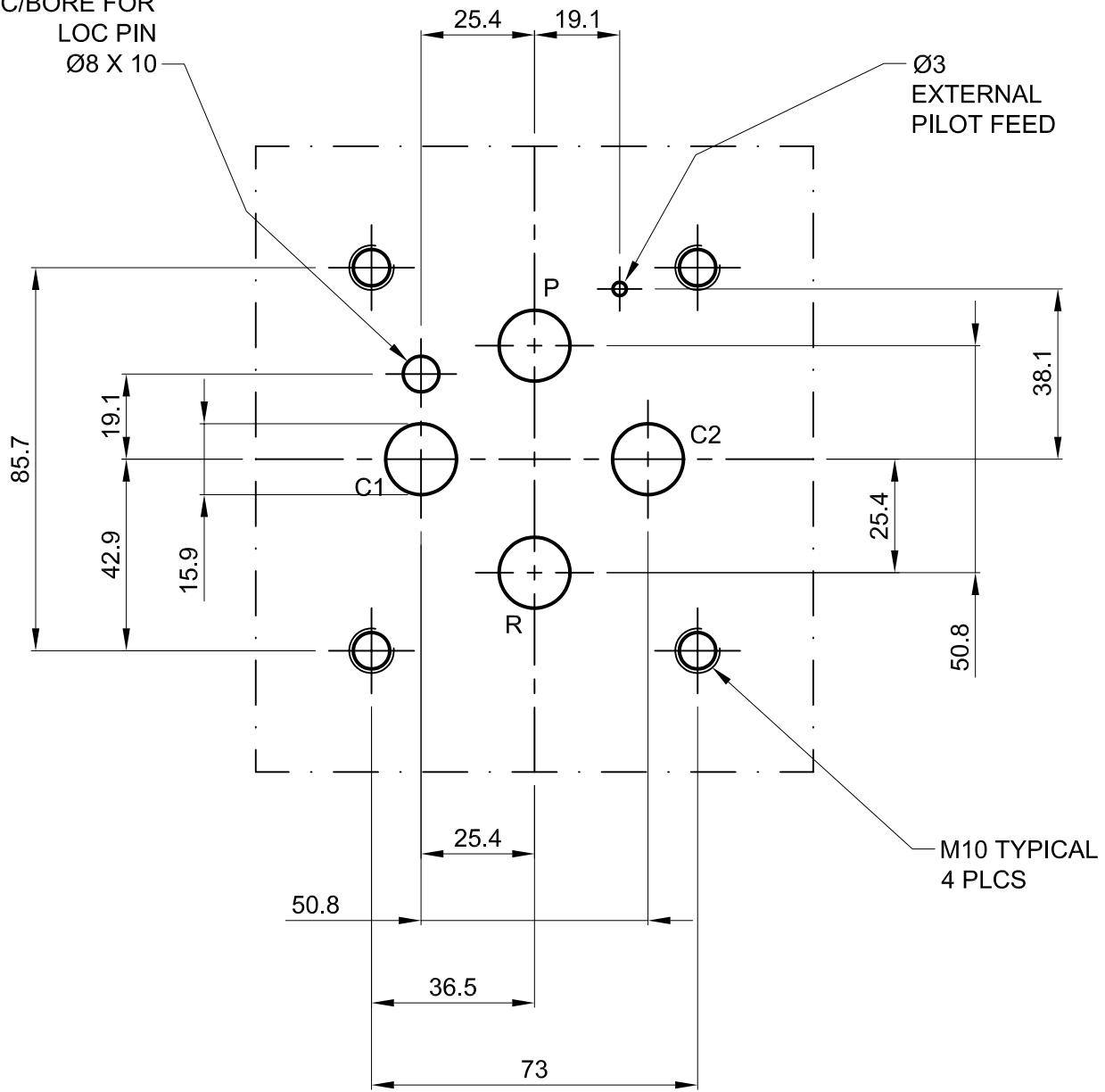

M10 TYPICAL
4 PLCS

Manifold Dimensions Model 892

Dimensions in millimeters
3rd angle projection

Filename

